



General Certificate of Conformity

1	<p>Covered product(s) Identification of the product covered by this certificate</p>	<p><i>Premium Labs product listed below:</i> Decoded – 30ml (all SKUs) I can't believe it's not Donuts – 30ml (all SKUs) World's Best Custards – 30ml (all SKUs) Dr. Fog All Stars – 30ml (all SKUs) Dr. Fog – 30ml (all SKUs) The Blind Pig – 30ml (all SKUs) Dr. Fog's Yummy Yogurts – 30ml (all SKUs) PI – 30ml (all SKUs) Kaktus – 30ml (all SKUs) Dr. Fog's Famous Ice Cream – 30ml (all SKUs) Domin8 – 30ml (all SKUs) Distinct – 30ml (all SKUs) Convicted Vapes – 30ml (all SKUs) Currency – 30ml (all SKUs)</p>
2	<p>Applicable Requirements Citation to each consumer product safety regulation to which this product is being certified</p>	<p>16 CFR Title 16 Part 1700.20</p>
3	<p>Manufacturer / Importer of Record Identification of the U.S. importer or domestic manufacturer certifying compliance of the product</p>	<p>Premium Labs Inc. 401 Ryland St. Ste 200A Reno, NV. 89502 1-888-554-5756</p>
4	<p>Custodian of Records Contact information for the individual maintaining records of test results</p>	<p>Maryam Darvish 401 Ryland St. Ste 200A Reno, NV. 89502 1-888-554-5756</p>
5	<p>Date and Place of Manufacture Date and place where this product was manufactured:</p>	<p>Manufactured by Glopak China for Glopak U.S.A. Check delivery box for date bottles were manufactured</p>
6	<p>Date and Place of Testing Provide the date(s) and place when the product was tested for compliance with the consumer product safety rule(s) cited above</p>	<p>Lancaster, PA, U.S.A. May 15 – June 12, 2015</p>
7	<p>Laboratory Identification of any third party laboratory on who's testing the certificate depends</p>	<p>Bird Dog Marketing Group, LLC 166 Farmington Lane Lancaster, PA 17601 717-475-9751 and 717-615-9022</p>



1345 East State Street | Eagle, ID 83616 | www.containerandpackaging.com | Toll free: 1-800-473-4144 | Fax: 208-939-0461

July 12, 2016

To Whom It May Concern:

This documentation certifies that the pairings listed below have been tested by an independent third party and meet the requirements dictated by 16 CFR 1700:

M031 + G068C, G141A, G141B, G141G, G068B, G068BK, G068F, G068G, G068P, G068R, G068W

Sincerely,

Container & Packaging Supply
Supply Chain Management Division

A note about certifications

A 16 CFR 1700 certification is awarded to the *combination* of a container and a closure, aka a package. In order to be compliant, and to have the proper certifications, the container *and* closure *combination* must be tested *together* by a third party.

This certification only permits the combinations listed above. This certification is nullified if you combine any of these listed items with any other item.



“We Point Toward Product Solutions”

**100 Unit Senior-Adult Resecuring Protocol Test
May 15, 2015 - June 12, 2015**

**Conducted for:
Glopak USA Corp**

Test No.:
GLO15-05A

Sample Type
30 mL Vial with 20-400 Cap

**Bird Dog Marketing Group, LLC
166 Farmington Lane
Lancaster, PA 17601
(717) 475-9751
(717) 615-9022**



Test Objective & Procedures

Bird Dog Marketing Group, LLC

Test Id: GLO15-05A

Customer Test No:

Test Description: **100 Unit Senior-Adult Resecuring Protocol Test
May 15, 2015 - June 12, 2015**

Report to: Glopak USA Corp
1816 127th Street 2F
College Point, NY 11356

30 mL Vial with 20-400 Cap

OBJECTIVE

Glopak USA Corp submitted the following test for evaluation by Bird Dog Marketing Group, LLC to see if it meets the senior-adult (50-70 years of age) resecuring criteria set forth by the C.P.S.C. for poison prevention packaging.

PROCEDURE

This test follows the guidelines set forth by the C.P.S.C., and published in the Federal Register on July 21, 1995 pgs. 37710-37744 re 16 CFR part 1700.15 and 1700.20.

DISCLAIMER

Bird Dog Marketing Group, LLC (Lancaster, PA. USA) is an independent marketing research firm specializing in field testing of child-resistant packages. It is to be noted that to the best of our knowledge, there are no commercial and or conflicts of interest between Bird Dog Marketing Group, LLC and Glopak USA Corp at the time of this study. The results of this protocol are based only on the data collected and the guidelines set forth by the C.P.S.C. under 16 CFR parts 1700.15 and 1700.20

Customer Test No:

Test Description: **100 Unit Senior-Adult Resecuring Protocol Test
May 15, 2015 - June 12, 2015**

Report to: Glopak USA Corp
1816 127th Street 2F
College Point, NY 11356

30 mL Vial with 20-400 Cap

Picture





Test Results and Discussion

Bird Dog Marketing Group, LLC

Test Id: GLO15-05A

Customer Test No:

Test Description: **100 Unit Senior-Adult Resecuring Protocol Test
May 15, 2015 - June 12, 2015**

RESULTS AND DISCUSSION

RESULTS AND DISCUSSION:

Test GLO15-05A consisted of one-hundred (100) adults (50-70 years of age) being tested in fifteen (15) sites from May 15, 2015 through June 12, 2015. This test is a one-hundred (100) unit senior-adult (50-70 years of age) resecuring protocol as set forth by the C.P.S.C., and published in the Federal Register on July 21, 1995 pgs. 37710-37744 re 16 CFR part 1700.15 and 1700.20.

The results of this study are as follows.

- 1) ONE (1) of the senior-adults failed to open their first package.
- Refer to Adult Resecuring Test Detail Report
- 2) TWO (2) of the senior-adults failed to open their second package.
- Refer to Adult Resecuring Test Detail Report
- 3) There were FOUR (4) child openings (refer to GLO15-05C - Child Portion)
- 4) Since less than 20% of the packages ($97 \times 0.2 = 19.40$) were opened by the children (refer to test GLO15-05C - Child Portion), no subtraction in score was needed from the senior-adult (SAUE) opening and resecuring results.
- 5) The C.P.S.C. requires a SAUE of no less than 90.00%.
- 6) The SAUE for this package is 97.00% with 100 adults tested.
- 7) Based on the results of this test, the submitted package meets the senior-adult criteria set forth by the C.P.S.C., as published in the Federal Register dated July 21, 1995 pgs. 37710-37744 re 16 CFR part 1700.15 and 1700.20

TEST PACKAGE DESCRIPTION:

The package used for test GLO15-05A was a 30 mL Vial with 20-400 Cap.

The composition of the package and its component information is as follows:

CLOSURE (20/400 CRC Dropper):

Description: Child Resistant Dropper Caps

Lot #: 02252015GP

Cap(inner, outer): Polypropylene (PP)

Rubber bulb: Silicon

Colorant: Black/White

BOTTLE (30ml Boston Bottle):

Description: e-juice bottle

Lot #: 022012015GP

Resin: Glass

Colorant: Clear



Test Results and Discussion

Bird Dog Marketing Group, LLC

Test Id: GLO15-05A

Customer Test No:

Test Description: **100 Unit Senior-Adult Resecuring Protocol Test
May 15, 2015 - June 12, 2015**

The instructions on the closure explaining how to open and resecure the package read: "PUSH DOWN WHILE TURNING --- CLOSE TIGHTLY".

A picture of the test package appears on Page 3.

PACKAGE PREPARATION:

- 1) Bird Dog Marketing Group, LLC received test sample packages in April of 2015.
- 2) The packages were prepared by Bird Dog Marketing Group, LLC and set at 12 torque-in.-lbs. per Glopak USA Corp.

Submitted by: Mark D. Perkins

A handwritten signature in black ink that reads 'Mark D Perkins' in a cursive script.

Senior Member



Adult-Child Resistant Packages Test Summary Report

Bird Dog Marketing Group, LLC

Test Id: GLO15-05A

Customer Test No:

Test Description: **100 Unit Senior-Adult Resecuring Protocol Test**
May 15, 2015 - June 12, 2015

Gender	Age Group/ Years	No. of Adults Tested	No. Failed to Open		No. of Packages that Children		Percentage of child openings	Adult Success Percentage
			Pkg 1	Pkg 2	Tested	Opened		
Female	50-54	18	0.00	0.00	18.00	1.00	5.56	100.00
Male	50-54	7	0.00	0.00	7.00	0.00	0.00	100.00
		25	0.00	0.00	25.00	1.00	4.00	100.00
Female	55-59	17	0.00	0.00	17.00	1.00	5.88	100.00
Male	55-59	8	0.00	0.00	8.00	2.00	25.00	99.60
		25	0.00	0.00	25.00	3.00	12.00	100.00
Female	60-70	35	1.00	2.00	32.00	0.00	0.00	91.43
Male	60-70	15	0.00	0.00	15.00	0.00	0.00	100.00
		50	1.00	2.00	47.00	0.00	0.00	94.00
Report Totals:		100	1.00	2.00	97.00	4.00	4.12	97.00

SAUE



Proctor Participation Report

Bird Dog Marketing Group, LLC

Test Id: GLO15-05A

Customer Test No:

Test Description: **100 Unit Senior-Adult Resecuring Protocol Test**
May 15, 2015 - June 12, 2015

No. of Test Participants: 100.00

Max. Participants per Proctor: 35.00 %

Proctor Id	Name	No. of Males	No. of Females	Total No.	Percent
DCP	Debra Perkins	17	14	31	31.00
JAP	Jordan Perkins	1	11	12	12.00
JMG	Jodi Gearhart	8	14	22	22.00
TMR	Tina Ries	4	31	35	35.00
Report Totals:		<u><u>30</u></u>	<u><u>70</u></u>	<u><u>100</u></u>	



Site Participation Report

Bird Dog Marketing Group, LLC

Test Id: GLO15-05A

Customer Test No:

Test Description: **100 Unit Senior-Adult Resecuring Protocol Test**
May 15, 2015 - June 12, 2015

No. of Test Participants: 100.00
 Max. Participants per Site: 24.00 %

Site Id	Description	No. of Males	No. of Females	Total No.	Percent
AMELLH	Amelias - Lincoln Highway	3	0	3	3.00
AMELNH	Amelias - New Holland	0	5	5	5.00
CAA	Chesterbrook Academy-Airport Rd.	2	0	2	2.00
CMH	Columbia Market House	0	2	2	2.00
FL	Foodland	3	9	12	12.00
LHR	Lancaster Host Resort	12	0	12	12.00
MC	Musser's - Columbia	2	3	5	5.00
QH	Quentin Haus	2	7	9	9.00
RCV	Relay Conestoga Valley High School	0	5	5	5.00
RM	Root's Farm Market	1	22	23	23.00
RTC	Route Thirty Center	3	4	7	7.00
SJCB	Saint James Church Bingo	1	0	1	1.00
SMS	Shady Maple Smorgasboard	0	4	4	4.00
SPSF	St. Peter's Strawberry Festival	1	7	8	8.00
WA	Weaver's Adamstown	0	2	2	2.00
Report Totals:		30	70	100	



Age Distribution Report

Bird Dog Marketing Group, LLC

Test Id: GLO15-05A

Customer Test No:

Test Description: **100 Unit Senior-Adult Resecuring Protocol Test**
May 15, 2015 - June 12, 2015

Age (Years)	No. of Males	No. of Females	Total Participants
50	0	7	7
51	3	4	7
52	0	3	3
53	2	2	4
54	2	2	4
55	1	2	3
56	2	3	5
57	1	3	4
58	1	6	7
59	3	3	6
60	1	1	2
61	1	4	5
62	0	5	5
63	2	2	4
64	0	5	5
65	2	4	6
66	2	2	4
67	1	3	4
68	4	3	7
69	0	3	3
70	2	3	5
Report Totals:	30	70	100



Adult-Child Resistant Packages Test Detail Report

Bird Dog Marketing Group, LLC

Test Id: GLO15-05A

Customer Test No:

Test Description: **100 Unit Senior-Adult Resecuring Protocol Test**
May 15, 2015 - June 12, 2015

Sample No.	M/F	Age Grp/ Years	Test Date	Birth-Date	Age/ Year	Site Id	Proctor Id	Package #1			Package #2			Pkg Not Opened by Child	Ease Code
								Removal (Sec.)	Secure (Sec.)	Total (Sec.)	Removal (Sec.)	Secure (Sec.)	Total (Sec.)		
053	F	50-54	6/6/2015	2/14/1963	52	SPSF	JAP	6	2	8	15	2	17	Y	Hard
054	F	50-54	6/6/2015	6/24/1962	52	SPSF	DCP	15	1	16	3	1	4	Y	Average
055	F	50-54	6/6/2015	5/29/1962	53	SPSF	JAP	8	2	10	9	3	12	Y	Hard
056	F	50-54	6/6/2015	2/7/1964	51	SPSF	JAP	19	2	21	12	4	16	Y	Hard
057	F	50-54	6/6/2015	3/28/1964	51	SPSF	JAP	14	2	16	2	2	4	Y	Average
058	F	50-54	6/6/2015	10/9/1964	50	SPSF	JAP	7	2	9	6	2	8	Y	Average
059	F	50-54	6/6/2015	9/3/1964	50	SPSF	JAP	11	2	13	4	2	6	Y	Easy
060	F	50-54	6/9/2015	7/26/1964	50	SMS	JMG	5	2	7	14	2	16	Y	Average
061	F	50-54	6/9/2015	9/12/1961	53	SMS	JMG	10	2	12	7	2	9	Y	Average
062	F	50-54	6/9/2015	3/24/1965	50	SMS	JMG	10	2	12	3	2	5	Y	Average
063	F	50-54	6/9/2015	2/19/1965	50	SMS	JMG	15	2	17	9	2	11	Y	Average
064	F	50-54	6/10/2015	8/18/1964	50	WA	JMG	9	2	11	13	2	15	Y	Hard
065	F	50-54	6/10/2015	7/11/1964	50	WA	JMG	10	2	12	8	2	10	N	Average
066	F	50-54	6/12/2015	12/26/1962	52	RCV	JAP	6	2	8	20	2	22	Y	Average
067	F	50-54	6/12/2015	4/10/1964	51	RCV	JAP	7	2	9	4	2	6	Y	Average
068	F	50-54	6/12/2015	7/20/1960	54	RCV	JAP	11	2	13	6	2	8	Y	Average
069	F	50-54	6/12/2015	6/27/1960	54	RCV	JAP	7	2	9	3	2	5	Y	Easy
070	F	50-54	6/12/2015	12/10/1963	51	RCV	JAP	7	2	9	6	2	8	Y	Average
088	M	50-54	5/20/2015	9/21/1961	53	FL	DCP	4	4	8	5	2	7	Y	Easy
090	M	50-54	5/22/2015	12/10/1960	54	QH	TMR	8	2	10	2	2	4	Y	Easy
091	M	50-54	5/22/2015	9/12/1960	54	QH	TMR	3	2	5	2	2	4	Y	Easy
094	M	50-54	6/1/2015	10/28/1961	53	SJCB	TMR	7	2	9	3	2	5	Y	Average
096	M	50-54	6/2/2015	3/12/1964	51	CAA	JMG	4	2	6	3	2	5	Y	Easy
098	M	50-54	6/3/2015	12/9/1963	51	AMELLH	JMG	6	2	8	15	2	17	Y	Easy
099	M	50-54	6/3/2015	4/23/1964	51	AMELLH	JMG	4	2	6	2	2	4	Y	Average
006	F	55-59	5/19/2015	12/31/1956	58	RM	TMR	4	2	6	2	2	4	Y	Easy
009	F	55-59	5/19/2015	2/20/1958	57	RM	TMR	4	2	6	9	2	11	Y	Average
015	F	55-59	5/19/2015	5/21/1957	57	RM	TMR	9	2	11	20	2	22	N	Hard
019	F	55-59	5/19/2015	3/15/1959	56	RM	TMR	33	2	35	12	2	14	Y	Average
020	F	55-59	5/19/2015	5/10/1957	58	RM	TMR	15	2	17	10	2	12	Y	Hard
022	F	55-59	5/19/2015	6/22/1956	58	RM	TMR	11	2	13	5	2	7	Y	Hard
025	F	55-59	5/19/2015	12/28/1956	58	RM	TMR	20	2	22	12	2	14	Y	Average
043	F	55-59	5/26/2015	9/15/1958	56	AMELNH	JMG	23	2	25	17	2	19	Y	Hard
044	F	55-59	5/26/2015	2/22/1956	59	AMELNH	JMG	28	2	30	15	2	17	Y	Average
045	F	55-59	5/26/2015	6/25/1957	57	AMELNH	JMG	34	2	36	3	2	5	Y	Very Hard
046	F	55-59	5/26/2015	2/25/1959	56	AMELNH	JMG	3	2	5	6	2	8	Y	Easy
047	F	55-59	5/26/2015	12/17/1959	55	AMELNH	JMG	4	2	6	3	2	5	Y	Easy



Adult-Child Resistant Packages Test Detail Report

Bird Dog Marketing Group, LLC

Test Id: GLO15-05A

Customer Test No:

Test Description: **100 Unit Senior-Adult Resecuring Protocol Test**
May 15, 2015 - June 12, 2015

Sample No.	M/F	Age Grp/ Years	Test Date	Birth-Date	Age/ Year	Site Id	Proctor Id	Package #1			Package #2			Pkg Not Opened by Child	Ease Code
								Removal (Sec.)	Secure (Sec.)	Total (Sec.)	Removal (Sec.)	Secure (Sec.)	Total (Sec.)		
048	F	55-59	5/28/2015	7/10/1955	59	CMH	TMR	6	2	8	4	2	6	Y	Hard
049	F	55-59	5/28/2015	8/21/1959	55	CMH	TMR	5	2	7	3	2	5	Y	Easy
050	F	55-59	5/29/2015	7/10/1956	58	MC	JMG	5	2	7	27	2	29	Y	Average
051	F	55-59	5/29/2015	2/20/1957	58	MC	JMG	16	2	18	9	2	11	Y	Hard
052	F	55-59	5/29/2015	3/28/1956	59	MC	JMG	4	2	6	2	2	4	Y	Easy
086	M	55-59	5/19/2015	11/6/1956	58	RM	TMR	2	2	4	2	2	4	N	Easy
087	M	55-59	5/20/2015	1/31/1958	57	FL	DCP	10	2	12	2	2	4	Y	Hard
089	M	55-59	5/20/2015	4/8/1959	56	FL	JMG	6	2	8	5	2	7	Y	Hard
092	M	55-59	5/29/2015	11/23/1955	59	MC	JMG	12	2	14	4	2	6	Y	Average
093	M	55-59	5/29/2015	1/24/1959	56	MC	JMG	11	2	13	4	2	6	Y	Easy
095	M	55-59	6/2/2015	9/27/1955	59	CAA	JMG	4	2	6	4	2	6	Y	Easy
097	M	55-59	6/3/2015	8/4/1955	59	AMELLH	JMG	3	2	5	10	2	12	N	Average
100	M	55-59	6/6/2015	6/4/1960	55	SPSF	JAP	4	2	6	3	2	5	Y	Average
001	F	60-70	5/16/2015	10/12/1949	65	RTC	DCP	45	2	47	10	2	12	Y	Hard
002	F	60-70	5/16/2015	2/22/1946	69	RTC	DCP	5	2	7	19	2	21	Y	Average
003	F	60-70	5/16/2015	11/5/1944	70	RTC	DCP	25	2	27	20	2	22	Y	Hard
004	F	60-70	5/16/2015	10/19/1953	61	RTC	DCP	38	2	40	8	2	10	Y	Very Hard
005	F	60-70	5/19/2015	11/25/1946	68	RM	TMR	30	2	32	13	2	15	Y	Hard
007	F	60-70	5/19/2015	3/6/1951	64	RM	TMR	78	2	80	32	2	34	Y	Hard
008	F	60-70	5/19/2015	5/28/1953	61	RM	TMR	14	2	16	4	2	6	Y	Average
010	F	60-70	5/19/2015	7/10/1954	60	RM	TMR	7	2	9	10	2	12	Y	Average
011	F	60-70	5/19/2015	2/18/1953	62	RM	TMR	52	2	54	9	2	11	Y	Very Hard
012	F	60-70	5/19/2015	6/15/1945	69	RM	TMR	130	2	132	12	2	14	Y	Very Hard
013	F	60-70	5/19/2015	2/22/1950	65	RM	TMR	18	2	20	12	2	14	Y	Very Hard
014	F	60-70	5/19/2015	10/27/1951	63	RM	TMR	12	2	14	15	2	17	Y	Hard
016	F	60-70	5/19/2015	10/14/1950	64	RM	TMR	30	2	32	13	2	15	Y	Hard
017	F	60-70	5/19/2015	3/16/1948	67	RM	TMR	20	2	22	33	2	35	Y	Average
018	F	60-70	5/19/2015	5/22/1944	70	RM	TMR	10	2	12	57	2	59	Y	Hard
021	F	60-70	5/19/2015	9/22/1952	62	RM	TMR	11	2	13	4	2	6	Y	Easy
023	F	60-70	5/19/2015	12/21/1949	65	RM	TMR	11	2	13	5	2	7	Y	Hard
024	F	60-70	5/19/2015	5/11/1947	68	RM	TMR	30	2	32	5	2	7	Y	Easy
026	F	60-70	5/19/2015	10/3/1952	62	RM	TMR	15	2	17	4	2	6	Y	Average
027	F	60-70	5/20/2015	9/25/1945	69	FL	DCP	20	2	22	9	2	11	Y	Very Hard
028	F	60-70	5/20/2015	6/7/1949	65	FL	DCP	10	2	12	2	2	4	Y	Hard
029	F	60-70	5/20/2015	6/14/1950	64	FL	DCP	5	2	7	11	2	13	Y	Hard
030	F	60-70	5/20/2015	2/1/1945	70	FL	DCP	301		301			0		Very Hard
031	F	60-70	5/20/2015	8/6/1953	61	FL	DCP	20	2	22	5	2	7	Y	Average



Adult-Child Resistant Packages Test Detail Report

Bird Dog Marketing Group, LLC

Test Id: GLO15-05A

Customer Test No:

Test Description: **100 Unit Senior-Adult Resecuring Protocol Test**
May 15, 2015 - June 12, 2015

Sample No.	M/F	Age Grp/ Years	Test Date	Birth-Date	Age/ Year	Site Id	Proctor Id	Package #1			Package #2			Pkg Not Opened by Child	Ease Code
								Removal (Sec.)	Secure (Sec.)	Total (Sec.)	Removal (Sec.)	Secure (Sec.)	Total (Sec.)		
032	F	60-70	5/20/2015	2/9/1954	61	FL	DCP	10	2	12	15	2	17	Y	Hard
033	F	60-70	5/20/2015	4/7/1947	68	FL	DCP	2	2	4	7	2	9	Y	Average
034	F	60-70	5/20/2015	5/11/1953	62	FL	DCP	19	2	21	3	2	5	Y	Hard
035	F	60-70	5/20/2015	8/18/1950	64	FL	DCP	6	2	8	61		61		Very Hard
036	F	60-70	5/22/2015	3/24/1949	66	QH	TMR	9	2	11	7	2	9	Y	Hard
037	F	60-70	5/22/2015	4/30/1948	67	QH	TMR	26	2	28	7	2	9	Y	Hard
038	F	60-70	5/22/2015	5/8/1951	64	QH	TMR	5	2	7	11	2	13	Y	Average
039	F	60-70	5/22/2015	3/1/1953	62	QH	TMR	5	2	7	8	2	10	Y	Average
040	F	60-70	5/22/2015	9/2/1948	66	QH	TMR	49	2	51	4	2	6	Y	Hard
041	F	60-70	5/22/2015	12/7/1951	63	QH	TMR	28	2	30	16	2	18	Y	Average
042	F	60-70	5/22/2015	5/27/1947	67	QH	TMR	82	2	84	61		61		Very Hard
071	M	60-70	5/15/2015	6/28/1946	68	LHR	DCP	13	2	15	8	2	10	Y	Hard
072	M	60-70	5/15/2015	6/11/1944	70	LHR	DCP	12	2	14	2	2	4	Y	Average
073	M	60-70	5/15/2015	3/26/1947	68	LHR	DCP	2	2	4	2	2	4	Y	Easy
074	M	60-70	5/15/2015	8/30/1948	66	LHR	DCP	14	2	16	15	2	17	Y	Easy
075	M	60-70	5/15/2015	12/15/1953	61	LHR	DCP	116	2	118	7	2	9	Y	Average
076	M	60-70	5/15/2015	7/25/1944	70	LHR	DCP	15	2	17	12	2	14	Y	Average
077	M	60-70	5/15/2015	2/8/1948	67	LHR	DCP	15	2	17	14	2	16	Y	Hard
078	M	60-70	5/15/2015	4/19/1952	63	LHR	DCP	12	2	14	2	2	4	Y	Easy
079	M	60-70	5/15/2015	10/2/1948	66	LHR	DCP	15	2	17	9	2	11	Y	Average
080	M	60-70	5/15/2015	7/16/1946	68	LHR	DCP	12	2	14	21	2	23	Y	Average
081	M	60-70	5/15/2015	3/18/1955	60	LHR	DCP	5	2	7	2	2	4	Y	Average
082	M	60-70	5/15/2015	6/5/1951	63	LHR	DCP	17	2	19	5	2	7	Y	Average
083	M	60-70	5/16/2015	8/9/1949	65	RTC	DCP	6	2	8	23	2	25	Y	Average
084	M	60-70	5/16/2015	12/21/1949	65	RTC	DCP	6	2	8	6	2	8	Y	Average
085	M	60-70	5/16/2015	10/1/1946	68	RTC	DCP	6	2	8	3	2	5	Y	Average



Package Identification Report

Bird Dog Marketing Group, LLC

Test Id: GLO15-05A

Customer Test No:

Test Description: **100 Unit Senior-Adult Resecuring Protocol Test**
May 15, 2015 - June 12, 2015

Sample No.	Customer Package Id No.	Opening Method	Sample No.	Customer Package Id No.	Opening Method
001	001	Normal	038	038	Normal
002	002	Normal	039	039	Normal
003	003	Normal	040	040	Normal
004	004	Normal	041	041	Normal
005	005	Normal	042	042	
006	006	Normal	043	043	Normal
007	007	Normal	044	044	Normal
008	008	Normal	045	045	Normal
009	009	Normal	046	046	Normal
010	010	Normal	047	047	Normal
011	011	Normal	048	048	Normal
012	012	Normal	049	049	Normal
013	013	Normal	050	050	Normal
014	014	Normal	051	051	Normal
015	015	Normal	052	052	Normal
016	016	Normal	053	053	Normal
017	017	Normal	054	054	Normal
018	018	Normal	055	055	Normal
019	019	Normal	056	056	Normal
020	020	Normal	057	057	Normal
021	021	Normal	058	058	Normal
022	022	Normal	059	059	Normal
023	023	Normal	060	060	Normal
024	024	Normal	061	061	Normal
025	025	Normal	062	062	Normal
026	026	Normal	063	063	Normal
027	027	Normal	064	064	Normal
028	028	Normal	065	065	Normal
029	029	Normal	066	066	Normal
030	030		067	067	Normal
031	031	Normal	068	068	Normal
032	032	Normal	069	069	Normal
033	033	Normal	070	070	Normal
034	034	Normal	071	071	Normal
035	035		072	072	Normal
036	036	Normal	073	073	Normal
037	037	Normal	074	074	Normal



Package Identification Report

Bird Dog Marketing Group, LLC

Test Id: GLO15-05A

Customer Test No:

Test Description: **100 Unit Senior-Adult Resecuring Protocol Test**
May 15, 2015 - June 12, 2015

Sample No.	Customer Package Id No.	Opening Method	Sample No.	Customer Package Id No.	Opening Method
075	075	Normal			
076	076	Normal			
077	077	Normal			
078	078	Normal			
079	079	Normal			
080	080	Normal			
081	081	Normal			
082	082	Normal			
083	083	Normal			
084	084	Normal			
085	085	Normal			
086	086	Normal			
087	087	Normal			
088	088	Normal			
089	089	Normal			
090	090	Normal			
091	091	Normal			
092	092	Normal			
093	093	Normal			
094	094	Normal			
095	095	Normal			
096	096	Normal			
097	097	Normal			
098	098	Normal			
099	099	Normal			
100	100	Normal			

Specification(s)

其余

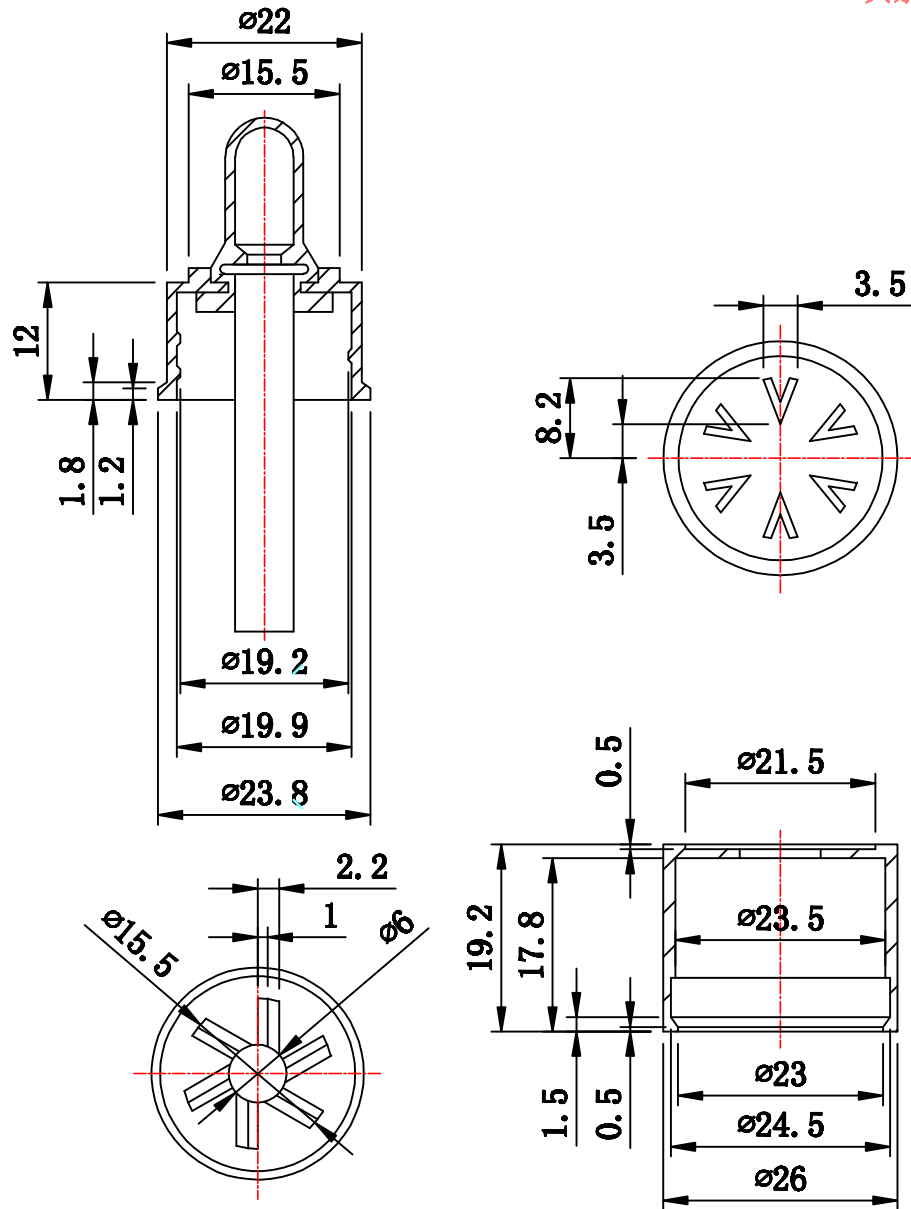

技术条件

- 1、未注公差极限偏差按GB/T 1804-m;
- 2、未注倒角0.5X45°;
- 3、未注倒圆R0.5;
- 4、表面本色。

客户登记

借(通)用件
登记

CAD

描 校

旧底图总号

底图总号

签 字

日 期

检验存档号

标记	处数	分区	更改文件号	签名	日期	图号				
设计			标准化			材质				
校对						图样标记	数量	重量	比例	
审核						版次	1		1:1	
工艺			审定			共 页	第 页			

1

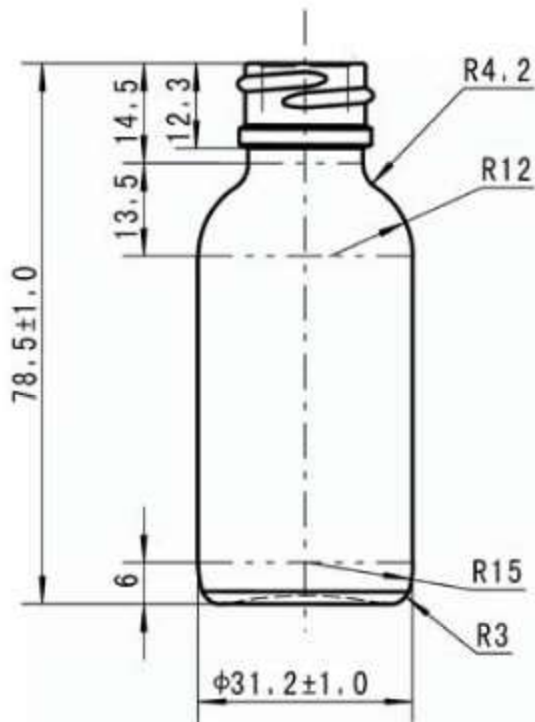

Thread D: 2.2mmmm
 Thread Pitch: 3.0mm
 N. of Turn: 1

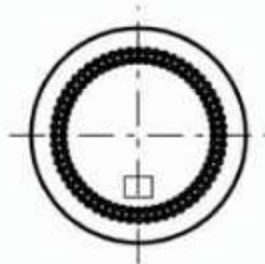

Neck Finish
 2: 1

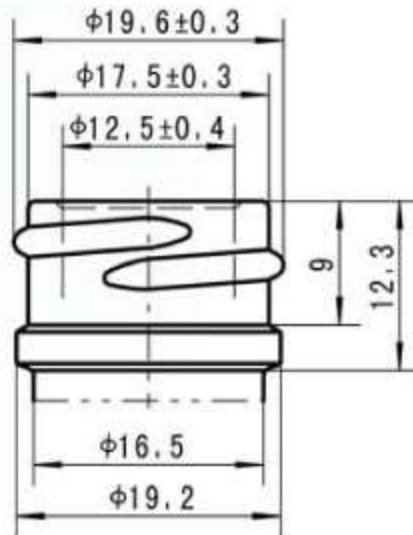

Nominal Capacity		Drawn	FengQi Cheng		Drawing Name	Scale
			Date	07, 10, 11		
O.F. Capacity	34 ± 2.5ml	Checked			Material	
			Date			
Weight	36g	Approved			GloPak USA Corp.	
			Date			

Certificate(s) of Compliance

Certificate of Completion

C.P.S.C. – Senior Adult Resecuring Protocol Test

awarded to

Glopak USA Corp

THIS IS TO CERTIFY THAT, the Glopak USA Corp 30 mL Vial with 20-400 Cap meets the Senior Adult criteria set forth by the C.P.S.C. and recorded in the Federal Register Section 16 CFR parts 1700.15 and 1700.20 dated July 21, 1995

Date of Completion: July 2, 2015

Signed: *Mark D Perkins*

Mark D. Perkins

Test Number: GLO15-05A/GLO15-05C

Package Description: 30 mL Vial with 20-400 Cap



ACCREDITED



BirdDog
Marketing Group LLC

166 Farmington Lane
Lancaster, PA 17601



Bird Dog
Marketing Group LLC

“We Point Toward Product Solutions”

**50 Unit Sequential Child Protocol Test
June 2, 2015 - July 1, 2015**

**Conducted for:
Glopak USA Corp**

Test No.:
GLO15-05SC

Sample Type
30 mL Vial with 20-400 Cap

**Bird Dog Marketing Group, LLC
166 Farmington Lane
Lancaster, PA 17601
(717) 475-9751
(717) 615-9022**



Test Objective & Procedures

Bird Dog Marketing Group, LLC

Test Id: GLO15-05SC

Customer Test No:

Test Description: **50 Unit Sequential Child Protocol Test
June 2, 2015 - July 1, 2015**

Report to: Glopak USA Corp
1816 127th Street 2F
College Point, NY 11356

30 mL Vial with 20-400 Cap

OBJECTIVE

Glopak USA Corp submitted the following test for evaluation by Bird Dog Marketing Group, LLC to see if it meets the child-resistant (42-51 months of age) criteria set forth by the C.P.S.C. for poison prevention packaging.

PROCEDURE

This test follows the guidelines set forth by the C.P.S.C., and published in the Federal Register on July 21, 1995 pgs. 37710-37744 re 16 CFR parts 1700.15 and 1700.20.

DISCLAIMER

Bird Dog Marketing Group, LLC (Lancaster, PA. USA) is an independent marketing research firm specializing in field testing of child-resistant packages. It is to be noted that to the best of our knowledge, there are no commercial and or conflicts of interest between Bird Dog Marketing Group, LLC and Glopak USA Corp at the time of this study. The results of this protocol are based only on the data collected and the guidelines set forth by the C.P.S.C. under 16 CFR parts 1700.15 and 1700.20

Customer Test No:

Test Description: **50 Unit Sequential Child Protocol Test**
June 2, 2015 - July 1, 2015

Report to: Glopak USA Corp
1816 127th Street 2F
College Point, NY 11356

30 mL Vial with 20-400 Cap

Picture





Test Results and Discussion

Bird Dog Marketing Group, LLC

Test Id: GLO15-05SC

Customer Test No:

Test Description: **50 Unit Sequential Child Protocol Test**
June 2, 2015 - July 1, 2015

RESULTS AND DISCUSSION

RESULTS AND DISCUSSION:

Test GLO15-05SC consisted of fifty (50) children (42-51 months) being tested in twelve (12) sites from June 2, 2015 through July 1, 2015. This test is a 50 unit sequential child (42-51 months of age) portion of a full 200 child protocol as per the final rule set forth by the C.P.S.C. dated July 21, 1995 pgs. 37710-37744 re 16 CFR parts 1700.15 and 1700.20

The results of the study are as follows:

1) A child failure is defined as any child who opens the package

2) NONE (0) of the children were able to open their package before demonstration

- Refer to Child Test Detail Report

3) NONE (0) of the children were able to open their package after demonstration

- Refer to Child Test Detail Report

4) The CPSC requires a child-resistant effectiveness of no less than 94.00% percent before demonstration and 90.00% after demonstration with 50 children tested

5) The child-resistant effectiveness for this package is 100.00% percent before demonstration and 100.00% after demonstration with 50 children tested

6) Based on the results of this test, the submitted package has met the criteria set forth by the C.P.S.C., as published in the Federal Register dated July 21, 1995 pgs. 37710-37744 re 16 CFR part 1700.15 and 1700.20.

TEST PACKAGE DESCRIPTION:

The package used for test GLO15-05SC was a 30 mL Vial with 20-400 Cap.

The composition of the package and its component information is as follows:

CLOSURE (20/400 CRC Dropper):

Description: Child Resistant Dropper Caps

Lot #: 02252015GP

Cap(inner, outer): Polypropylene (PP)

Rubber bulb: Silicon

Colorant: Black/White

BOTTLE (30ml Boston Bottle):

Description: e-juice bottle

Lot #: 022012015GP

Resin: Glass

Colorant: Clear



Test Results and Discussion

Bird Dog Marketing Group, LLC

Test Id: GLO15-05SC

Customer Test No:

Test Description: **50 Unit Sequential Child Protocol Test**
June 2, 2015 - July 1, 2015

The instructions on the closure explaining how to open and resecure the package read: "PUSH DOWN WHILE TURNING --- CLOSE TIGHTLY".

A picture of the test package appears on Page 3.

TEST PACKAGE PREPARATION:

- 1) Bird Dog Marketing Group, LLC received test sample packages in April of 2015.
- 2) The packages were prepared by Bird Dog Marketing Group, LLC and set at 12 torque-in.-lbs. per Glopak USA Corp.
- 3) All of the closures were removed and re-applied at 8.0 t.i.p. using a SecurePak Spring Torque Tester prior to presenting them to the children for protocol testing.
- 4) The testing agency numbered all of the packages (1-50) to track the testing results.

Submitted by: Mark D. Perkins

Senior Member



Child Resistant Packages Test Summary Report

Bird Dog Marketing Group, LLC

Test Id: GLO15-05SC

Customer Test No:

Test Description: **50 Unit Sequential Child Protocol Test**
June 2, 2015 - July 1, 2015

Gender	Age Group/ Months	No. of Children Tested	Before Demonstration	After Demonstration	Total
Female	42-44	7	0.00	0.00	0.00
Male	42-44	8	0.00	0.00	0.00
		<u>15</u>	<u>0.00</u>	<u>0.00</u>	<u>0.00</u>
Female	45-48	10	0.00	0.00	0.00
Male	45-48	10	0.00	0.00	0.00
		<u>20</u>	<u>0.00</u>	<u>0.00</u>	<u>0.00</u>
Female	49-51	8	0.00	0.00	0.00
Male	49-51	7	0.00	0.00	0.00
		<u>15</u>	<u>0.00</u>	<u>0.00</u>	<u>0.00</u>
Report Totals:		<u><u>50</u></u>	<u><u>0.00</u></u>	<u><u>0.00</u></u>	<u><u>0.00</u></u>



Proctor Participation Report

Bird Dog Marketing Group, LLC

Test Id: GLO15-05SC

Customer Test No:

Test Description: **50 Unit Sequential Child Protocol Test**
June 2, 2015 - July 1, 2015

No. of Test Participants: 50.00
Max. Participants per Proctor: 30.00 %

Proctor Id	Name	No. of Males	No. of Females	Total No.	Percent
DOW	Denise White	5	9	14	28.00
FMS	Fran Sensenig	6	1	7	14.00
KMS	Kellie Salvaggio	3	5	8	16.00
MSL	Stephany Lombardo	4	3	7	14.00
SJB	Sally Brinker	3	7	10	20.00
SMB	Susan Braswell	4	0	4	8.00
Report Totals:		<u><u>25</u></u>	<u><u>25</u></u>	<u><u>50</u></u>	



Site Participation Report

Bird Dog Marketing Group, LLC

Test Id: GLO15-05SC

Customer Test No:

Test Description: **50 Unit Sequential Child Protocol Test**
June 2, 2015 - July 1, 2015

No. of Test Participants: 50.00
 Max. Participants per Site: 20.00 %

Site Id	Description	No. of Males	No. of Females	Total No.	Percent
BB	Bright Beginnings - Clover Lane	3	7	10	20.00
GHCA	Grandview Christian Academy	1	1	2	4.00
GSY	The Goddard School	2	0	2	4.00
HALC	Hildebrandt Albright Learning Ctr.	3	1	4	8.00
HCB	Hildebrandt Creative Beginnings	1	0	1	2.00
HGELC	Hansel & Gretel Early Learning Cent	3	5	8	16.00
KCER	Kinder Care - E R	3	0	3	6.00
UGBR	U-Gow - Brighton	2	0	2	4.00
UGHACC	U Grow - HACC	2	5	7	14.00
UGIS	U-Grow - Indian Springs	0	3	3	6.00
UGY	U-Grow - York	5	0	5	10.00
YDN	York Day Nursery	0	3	3	6.00
Report Totals:		25	25	50	



Age Distribution Report

Bird Dog Marketing Group, LLC

Test Id: GLO15-05SC

Customer Test No:

Test Description: **50 Unit Sequential Child Protocol Test**
June 2, 2015 - July 1, 2015

Age (Months)	No. of Males	No. of Females	Total Participants
42	1	3	4
43	3	1	4
44	4	3	7
45	2	1	3
46	2	4	6
47	5	2	7
48	1	3	4
49	4	0	4
50	2	5	7
51	1	3	4
Report Totals:	25	25	50



Child Resistant Packages Test Detail Report

Bird Dog Marketing Group, LLC

Test Id: GLO15-05SC

Customer Test No:

Test Description: **50 Unit Sequential Child Protocol Test
June 2, 2015 - July 1, 2015**

Sample No.	Male/ Female	Age Group/ Months	Test Date	Birth- Date	Age/ Months	Site Id	Proctor Id	Method	Opening Seconds
04	F	42-44	6/25/2015	10/30/2011	44	HGELC	KMS		601
21	F	42-44	6/25/2015	10/17/2011	44	BB	SJB		601
25	F	42-44	7/1/2015	12/22/2011	42	UGHACC	DOW		601
34	F	42-44	7/1/2015	12/20/2011	42	UGHACC	DOW		601
36	F	42-44	6/25/2015	11/12/2011	43	HGELC	KMS		601
37	F	42-44	6/16/2015	12/27/2011	42	GHCA	FMS		601
40	F	42-44	7/1/2015	10/26/2011	44	UGHACC	DOW		601
05	M	42-44	6/30/2015	11/23/2011	43	UGY	FMS		601
07	M	42-44	6/25/2015	11/25/2011	43	BB	SJB		601
10	M	42-44	7/1/2015	10/28/2011	44	UGHACC	DOW		601
17	M	42-44	6/30/2015	12/27/2011	42	UGY	FMS		601
24	M	42-44	6/25/2015	11/22/2011	43	BB	SJB		601
27	M	42-44	7/1/2015	10/17/2011	44	UGHACC	DOW		601
33	M	42-44	6/25/2015	10/12/2011	44	HGELC	KMS		601
41	M	42-44	6/30/2015	11/7/2011	44	UGY	FMS		601
01	F	45-48	6/2/2015	5/28/2011	48	HALC	DOW		601
03	F	45-48	6/22/2015	6/26/2011	48	UGIS	DOW		601
08	F	45-48	6/22/2015	7/10/2011	47	UGIS	DOW		601
11	F	45-48	6/24/2015	8/20/2011	46	YDN	MSL		601
12	F	45-48	6/22/2015	8/29/2011	46	UGIS	DOW		601
18	F	45-48	6/25/2015	8/25/2011	46	HGELC	KMS		601
23	F	45-48	6/25/2015	6/16/2011	48	HGELC	KMS		601
29	F	45-48	6/24/2015	9/20/2011	45	YDN	MSL		601
39	F	45-48	6/24/2015	9/2/2011	46	YDN	MSL		601
44	F	45-48	6/25/2015	7/15/2011	47	BB	SJB		601
06	M	45-48	6/11/2015	8/5/2011	46	UGBR	MSL		601
09	M	45-48	6/10/2015	9/2/2011	45	KCER	SMB		601
14	M	45-48	6/10/2015	7/1/2011	47	KCER	SMB		601
15	M	45-48	6/10/2015	6/29/2011	47	KCER	SMB		601
20	M	45-48	6/2/2015	7/8/2011	47	HALC	DOW		601
22	M	45-48	6/2/2015	9/7/2011	45	HALC	DOW		601
30	M	45-48	6/2/2015	7/25/2011	46	HCB	SMB		601
35	M	45-48	6/16/2015	7/1/2011	47	GHCA	FMS		601
43	M	45-48	6/2/2015	6/8/2011	48	HALC	DOW		601
49	M	45-48	6/11/2015	7/8/2011	47	UGBR	MSL		601
02	F	49-51	6/25/2015	3/10/2011	51	BB	SJB		601
13	F	49-51	7/1/2015	3/24/2011	51	UGHACC	DOW		601
19	F	49-51	7/1/2015	5/16/2011	50	UGHACC	DOW		601



Child Resistant Packages Test Detail Report

Bird Dog Marketing Group, LLC

Test Id: GLO15-05SC

Customer Test No:

Test Description: **50 Unit Sequential Child Protocol Test
June 2, 2015 - July 1, 2015**

Sample No.	Male/ Female	Age Group/ Months	Test Date	Birth- Date	Age/ Months	Site Id	Proctor Id	Method	Opening Seconds
26	F	49-51	6/25/2015	4/15/2011	50	HGELC	KMS		601
28	F	49-51	6/25/2015	4/10/2011	50	BB	SJB		601
42	F	49-51	6/25/2015	4/14/2011	50	BB	SJB		601
48	F	49-51	6/25/2015	4/5/2011	51	BB	SJB		601
50	F	49-51	6/25/2015	4/15/2011	50	BB	SJB		601
16	M	49-51	6/30/2015	5/31/2011	49	UGY	FMS		601
31	M	49-51	6/26/2015	6/6/2011	49	GSY	MSL		601
32	M	49-51	6/26/2015	3/16/2011	51	GSY	MSL		601
38	M	49-51	6/25/2015	4/30/2011	50	HGELC	KMS		601
45	M	49-51	6/25/2015	6/8/2011	49	BB	SJB		601
46	M	49-51	6/30/2015	5/28/2011	49	UGY	FMS		601
47	M	49-51	6/25/2015	4/27/2011	50	HGELC	KMS		601



Package Identification Report

Bird Dog Marketing Group, LLC

Test Id: GLO15-05SC

Customer Test No:

Test Description: **50 Unit Sequential Child Protocol Test**
June 2, 2015 - July 1, 2015

Sample No.	Customer Package Id No.	Sample No.	Customer Package Id No.	Sample No.	Customer Package Id No.
01	01	39	39		
02	02	40	40		
03	03	41	41		
04	04	42	42		
05	05	43	43		
06	06	44	44		
07	07	45	45		
08	08	46	46		
09	09	47	47		
10	10	48	48		
11	11	49	49		
12	12	50	50		
13	13				
14	14				
15	15				
16	16				
17	17				
18	18				
19	19				
20	20				
21	21				
22	22				
23	23				
24	24				
25	25				
26	26				
27	27				
28	28				
29	29				
30	30				
31	31				
32	32				
33	33				
34	34				
35	35				
36	36				
37	37				
38	38				

Specification(s)

其余 

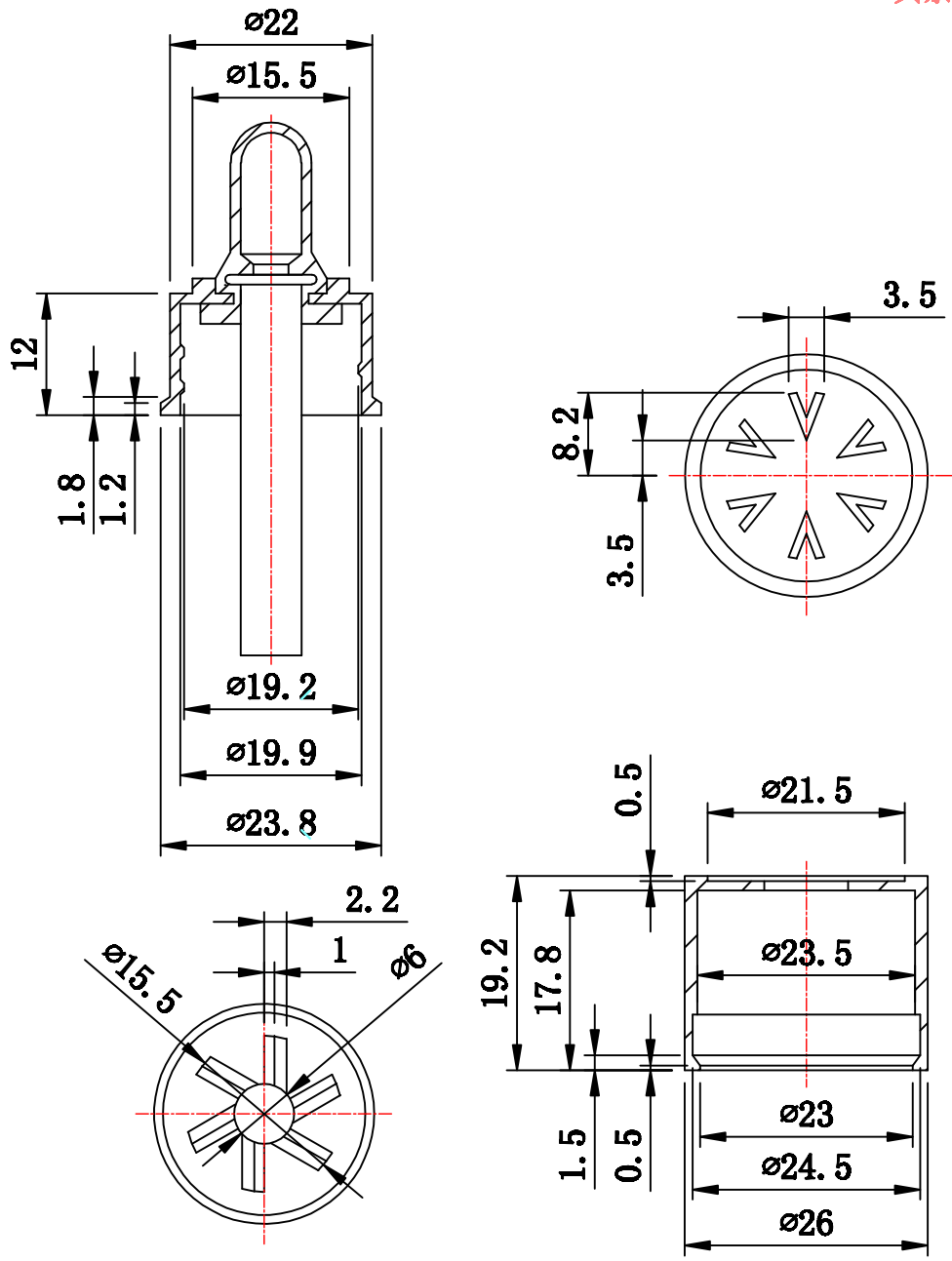

技术条件

- 1、未注公差极限偏差按GB/T 1804-m;
- 2、未注倒角0.5X45°;
- 3、未注倒圆R0.5;
- 4、表面本色。

客户登记

借(通)用件
登记
CAD

描 校

旧底图总号

底图总号

签 字

日 期

检验存管号

							型号		
							材 质		
标记	处数	分区	更改文件号	签名	日期		图样标记	数量	重量
设计			标准化					1	1:1
校对							版 次	A	
审核							共 页		第 页
工艺			审定						

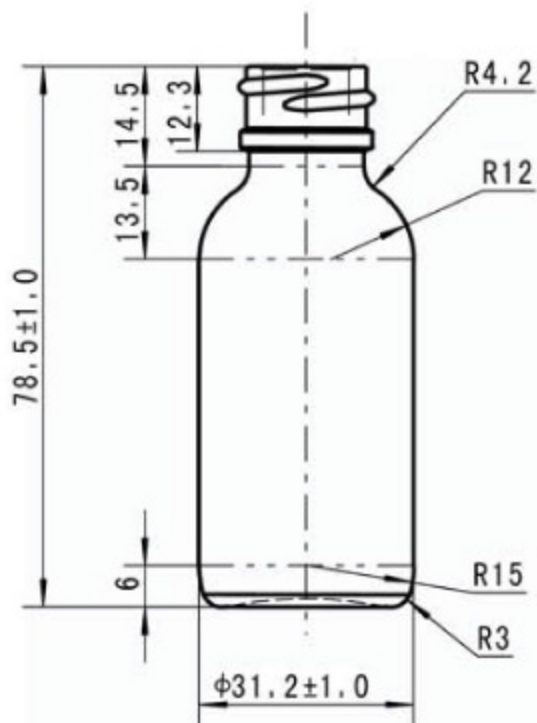

Thread D: 2.2mmmm
 Thread Pitch: 3.0mm
 N. of Turn: 1

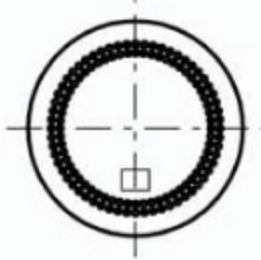

Neck Finish
 2: 1

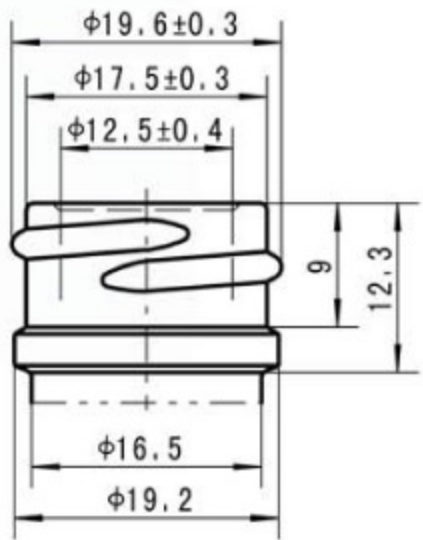

Nominal Capacity		Drawn	FengQi Cheng		Drawing Name	Scale
			Date	07.10.11		
O.F. Capacity	34 ± 2.5 ml	Checked			Material	
			Date			
Weight	36g	Approved			GloPak USA Corp.	
			Date			

Certificate(s) of Compliance

Certificate of Completion

C.P.S.C. – Child Resistant Protocol Test

awarded to

Glopak USA Corp

THIS IS TO CERTIFY THAT, the Glopak USA Corp 30 mL Vial with 20-400 Cap meets the child resistant criteria set forth by the C.P.S.C. and recorded in the Federal Register Section 16 CFR parts 1700.15 and 1700.20 dated July 21, 1995

Date of Completion: July 1, 2015

Signed: *Mark D. Perkins*

Mark D. Perkins

Test Number: GLO15-05SC

Package Description: 30 mL Vial with 20-400 Cap



ACCREDITED



BirdDog
Marketing Group LLC

166 Farmington Lane
Lancaster, PA 17601

